

FIRST FLOOR PLAN

3/16" = 1'-0"

First Floor:
 6,476 g.s.f. footprint, 842 s.f. circ/service (13% +/-)
 (3) 2 Beds units
 (3) 1 Bed units

Building Totals:
 12,559 g.s.f. , 1,530 s.f. circ/service (12% +/-)
 (6) 2 Beds units
 (6) 1 Bed units

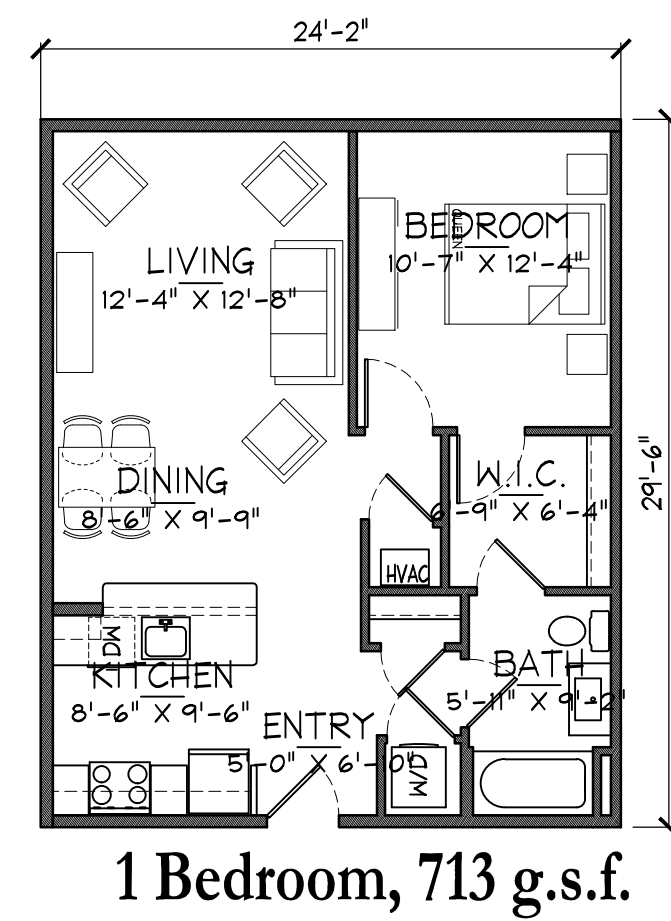

1 Bedroom, 713 g.s.f.

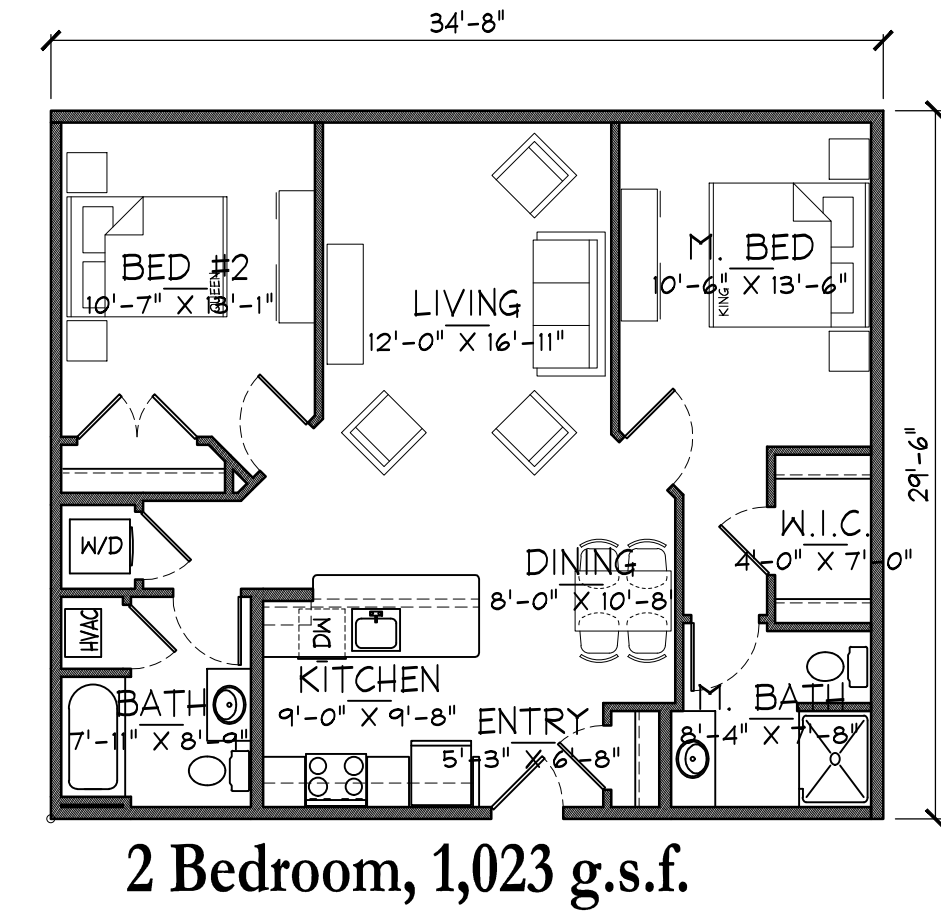

2 Bedroom, 1,023 g.s.f.

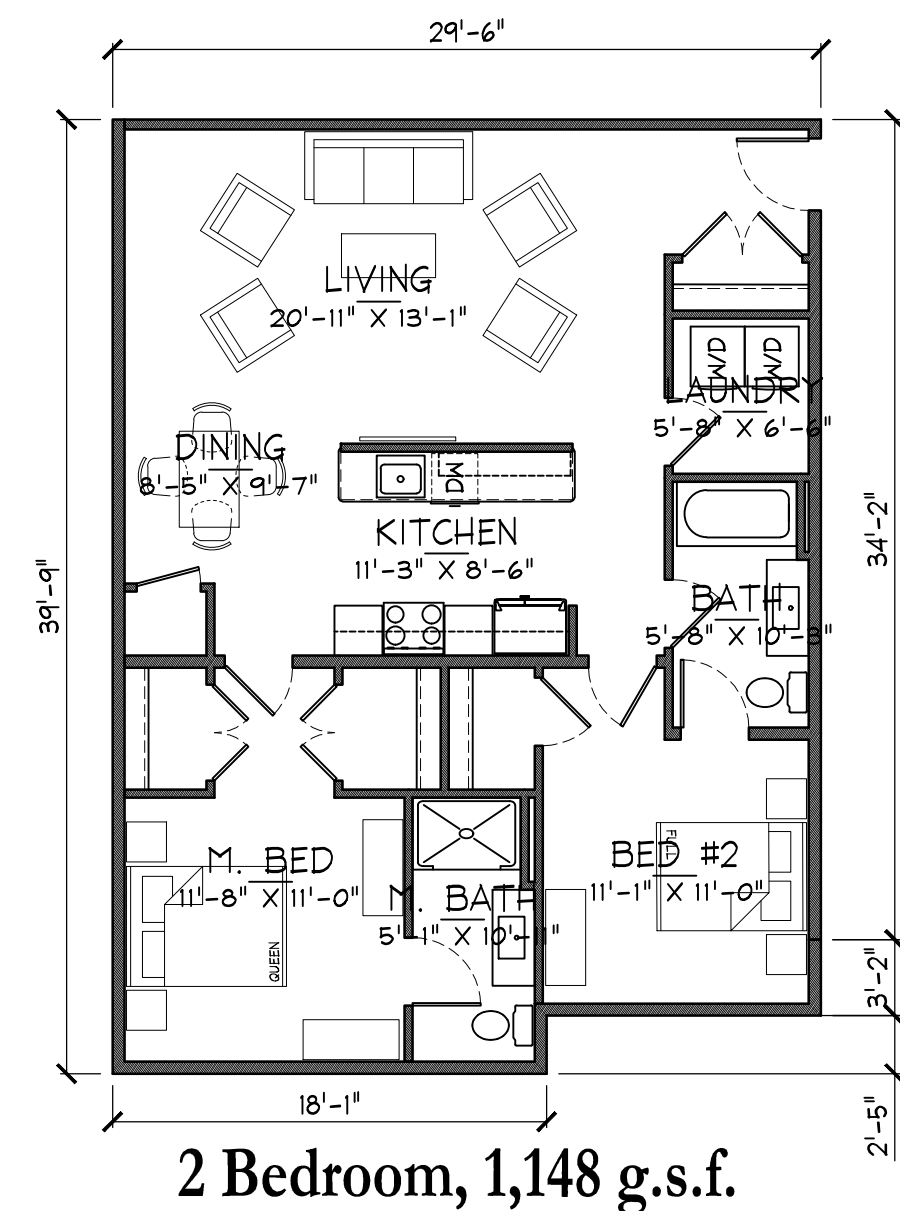

2 Bedroom, 1,148 g.s.f.

Unit Types

SEE BUILDING PLANS FOR ADDED S.F. AT PROJECTED GABLES

119 Partners LLC, Senior Housing

797 Boston Rd., Groton 04/17/2024

The MZO GROUP
 DESIGNERS ■ ARCHITECTS ■ PLANNERS
 IN THE *MIQUELLE* TRADITION

335 Main Street, Suite 201 ■ Stoneham, Massachusetts 02180
 Voice: 781-279-4446 ■ Fax: 781-279-4448 ■ E-Mail: mzo@mzogroup.com ■ www.mzogroup.com

© COPYRIGHT 2023 - MZO ARCHITECTURAL GROUP, INC. OWNS THE COPYRIGHT IN THIS DOCUMENT. NO REPRODUCTION OR OTHER USE IS ALLOWED WITHOUT THE EXPRESS WRITTEN CONSENT OF MZO ARCHITECTURAL GROUP, INC.

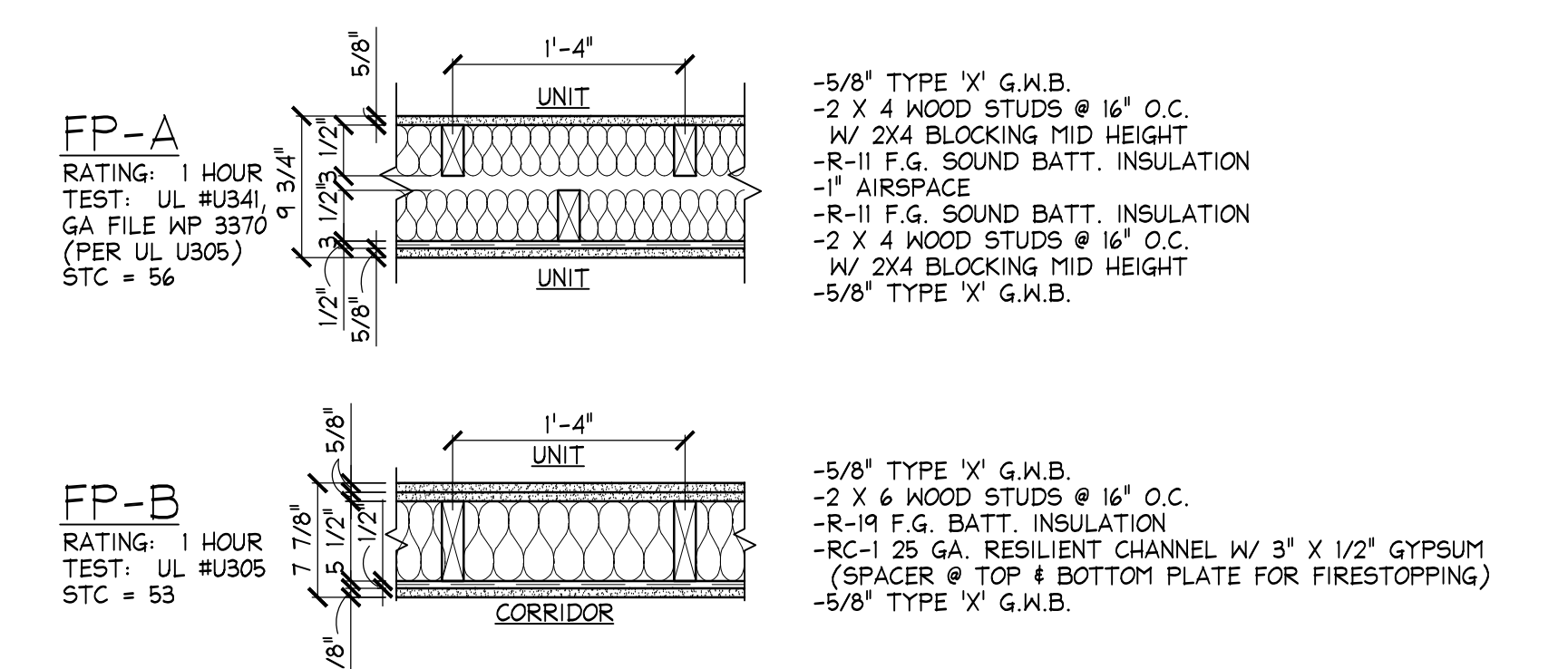

Second Floor:
 6,083 g.s.f., 688 s.f. circ/service (11% +/-)
 (3) 2 Beds units
 (3) 1 Bed units

SECOND FLOOR PLAN
 1/4" = 1'-0"

119 Partners LLC, Senior Housing
 797 Boston Rd., Groton 04/17/2024

The MZO GROUP
 DESIGNERS ■ ARCHITECTS ■ PLANNERS
 IN THE *MIQUELLE* TRADITION

335 Main Street, Suite 201 ■ Stoneham, Massachusetts 02180
 Voice: 781-279-4446 ■ Fax: 781-279-4448 ■ E-Mail: mzo@mzogroup.com ■ www.mzogroup.com

© COPYRIGHT 2023, MZO ARCHITECTURAL GROUP, INC. OWNS THE COPYRIGHT IN THIS DOCUMENT.
 NO REPRODUCTION OR OTHER USE IS ALLOWED WITHOUT THE EXPRESS WRITTEN CONSENT OF MZO ARCHITECTURAL GROUP, INC.

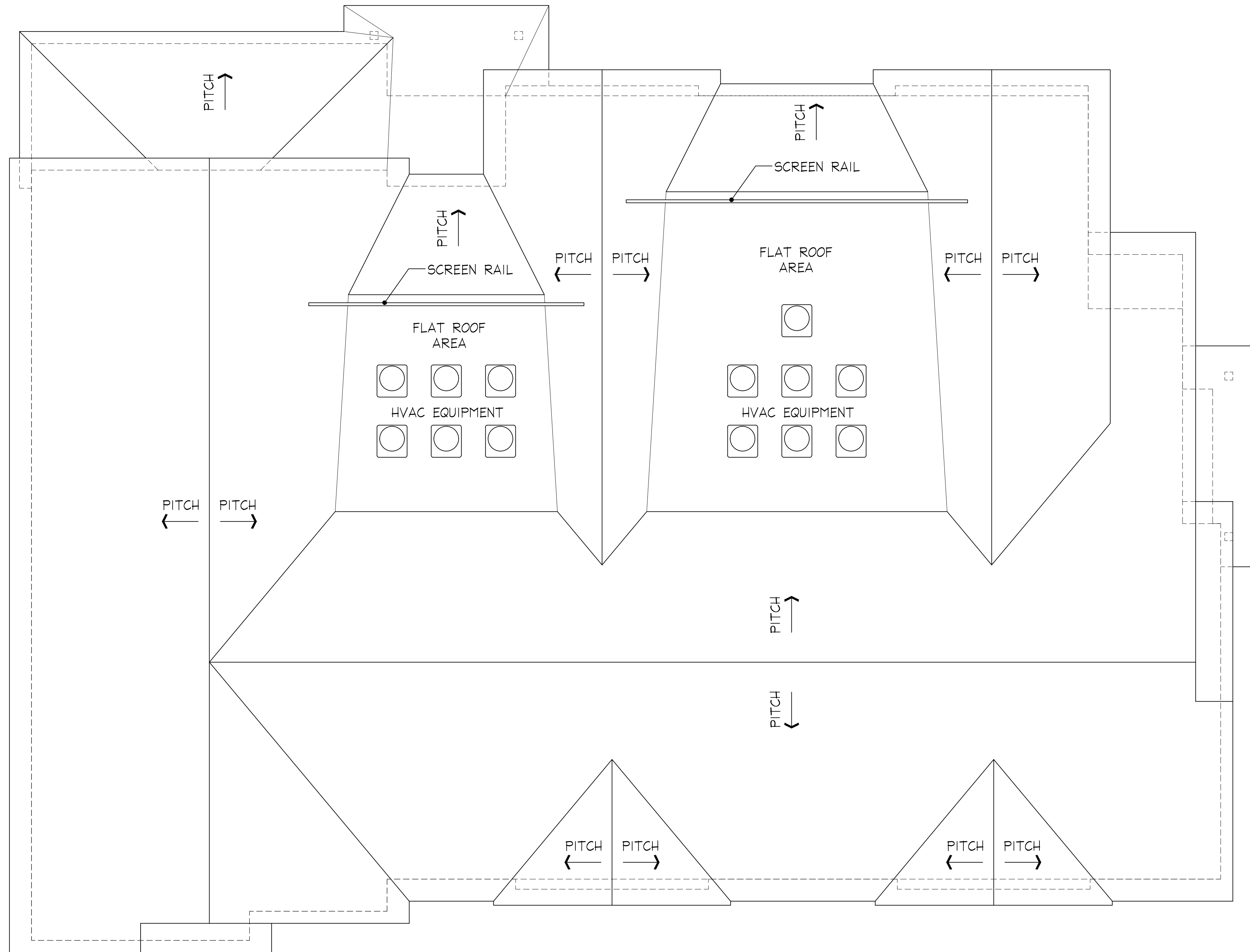

ROOF PLAN

1/4" = 1'-0"

119 Partners LLC, Senior Housing
 797 Boston Rd., Groton 04/17/2024

 **The MZO GROUP**
 DESIGNERS ■ ARCHITECTS ■ PLANNERS
 IN THE *MIQUELLE* TRADITION

335 Main Street, Suite 201 ■ Stoneham, Massachusetts 02180
 Voice: 781-279-4446 ■ Fax: 781-279-4448 ■ E-Mail: mzo@mzogroup.com ■ www.mzogroup.com

© COPYRIGHT 2023, MZO ARCHITECTURAL GROUP, INC. OWNS THE COPYRIGHT IN THIS DOCUMENT.
 NO REPRODUCTION OR OTHER USE IS ALLOWED WITHOUT THE EXPRESS WRITTEN CONSENT OF MZO ARCHITECTURAL GROUP, INC.



SOUTH ELEVATION - (BOSTON ROAD)

1/4" = 1'-0"



EAST ELEVATION

1/4" = 1'-0"

EXTERIOR FINISHES

- 1 CHARCOAL COLOR ARCHITECTURAL ROOF SHINGLES
- 2 WHITE EAVE AND RAKE TRIM
- 3 WHITE BOARD AND BATTEN VINYL SIDING
- 4 WHITE 5" EXPOSURE VINYL SIDING
- 5 BLACK VINYL WINDOWS
- 6 WOOD COLORED COMPOSITE NICKEL BD. SIDING

119 Partners LLC, Senior Housing
 797 Boston Rd., Groton 04/17/2024

The MZO GROUP
 DESIGNERS ■ ARCHITECTS ■ PLANNERS
 IN THE *MIQUELLE* TRADITION

335 Main Street, Suite 201 ■ Stoneham, Massachusetts 02180
 Voice: 781-279-4446 ■ Fax: 781-279-4448 ■ E-Mail: mzo@mzogroup.com ■ www.mzogroup.com

© COPYRIGHT 2023, MZO ARCHITECTURAL GROUP, INC. OWNS THE COPYRIGHT IN THIS DOCUMENT.
 NO REPRODUCTION OR OTHER USE IS ALLOWED WITHOUT THE EXPRESS WRITTEN CONSENT OF MZO ARCHITECTURAL GROUP, INC.

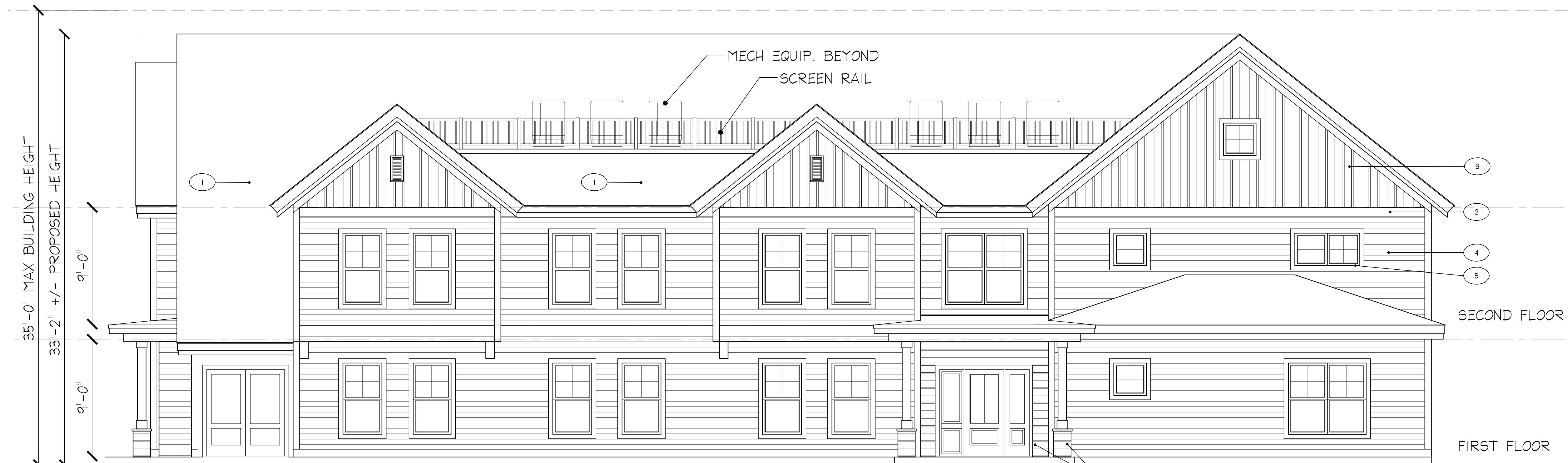

NORTH ELEVATION (PARKING)

1/4" = 1'-0"



WEST ELEVATION

1/4" = 1'-0"

EXTERIOR FINISHES	
1	CHARCOAL COLOR ARCHITECTURAL ROOF SHINGLES
2	WHITE EAVE AND RAKE TRIM
3	WHITE BOARD AND BATTEN VINYL SIDING
4	WHITE 5" EXPOSURE VINYL SIDING
5	BLACK VINYL WINDOWS
6	WOOD COLORED COMPOSITE NICKEL BD. SIDING

119 Partners LLC, Senior Housing
 797 Boston Rd., Groton
 04/17/2024

The MZO GROUP
 DESIGNERS ■ ARCHITECTS ■ PLANNERS
 IN THE *MIQUELLE* TRADITION

335 Main Street, Suite 201 ■ Stoneham, Massachusetts 02180
 Voice: 781-279-4446 ■ Fax: 781-279-4448 ■ E-Mail: mzo@mzogroup.com ■ www.mzogroup.com

© COPYRIGHT 2023, MZO ARCHITECTURAL GROUP, INC. OWNS THE COPYRIGHT IN THIS DOCUMENT.
 NO REPRODUCTION OR OTHER USE IS ALLOWED WITHOUT THE EXPRESS WRITTEN CONSENT OF MZO ARCHITECTURAL GROUP, INC.

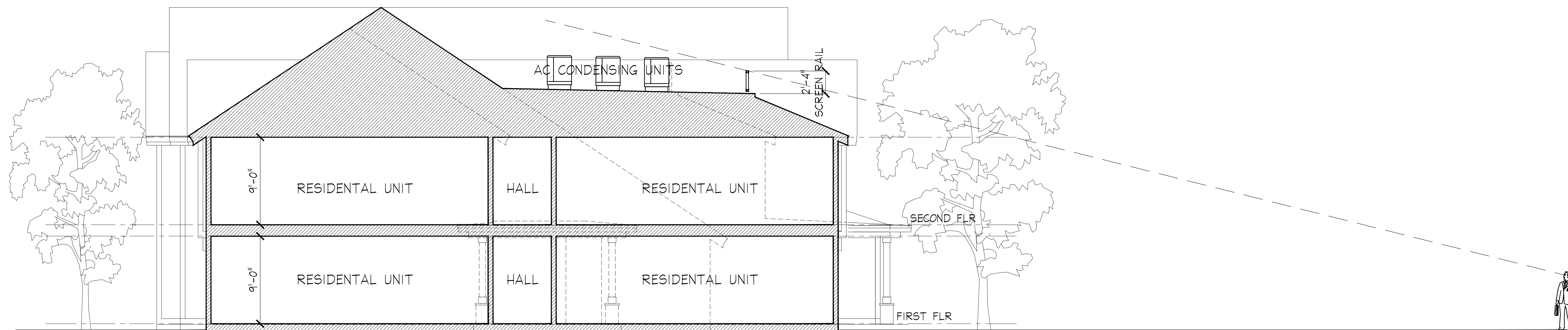

SECTION - HVAC SIGHT LINE DIAGRAM

3/16" = 1'-0"

119 Partners LLC, Senior Housing
 797 Boston Rd., Groton 04/17/2024

The MZO GROUP
 DESIGNERS ■ ARCHITECTS ■ PLANNERS
 IN THE *MIQUELLE* TRADITION

335 Main Street, Suite 201 ■ Stoneham, Massachusetts 02180
 Voice: 781-279-4446 ■ Fax: 781-279-4448 ■ E-Mail: mzo@mzogroup.com ■ www.mzogroup.com

© COPYRIGHT 2023, MZO ARCHITECTURAL GROUP, INC. OWNS THE COPYRIGHT IN THIS DOCUMENT.
 NO REPRODUCTION OR OTHER USE IS ALLOWED WITHOUT THE EXPRESS WRITTEN CONSENT OF MZO ARCHITECTURAL GROUP, INC.